

EMG-02

10 Stage Automatic Coilgun

User Manual

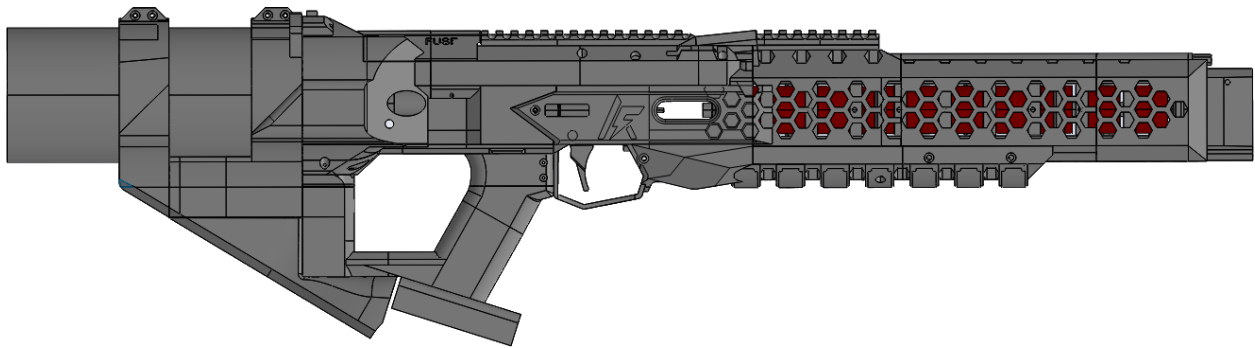

Arcflash Labs, LLC
8620 Belford Ave, Unit 603
Los Angeles CA 90045 - (424) 256-5087
www.arcflashlabs.com • admin@arcflashlabs.com

California Proposition 65 Warning: This product contains chemicals (lead) known to the state of California to cause cancer, birth defects and other reproductive harm. For more information: www.P65Warnings.ca.gov

Warranty: Arcflash Labs, LLC. (hereinafter referred to as "Arcflash Labs") warrants to the original purchaser these products to be free from defects in material and workmanship under normal conditions of use and service for a period of 30 days from date of shipment. Arcflash Labs will, as its option, repair, replace or refund the purchase price of any products that prove defective within the warranty period, if such products are returned to Arcflash Labs in accordance with the warranty claim procedures set forth below. REPAIR OR REPLACEMENT OF THESE PRODUCTS, OR REFUND OF THE PURCHASE PRICE AS PROVIDED UNDER THIS WARRANTY, IS THE BUYER'S EXCLUSIVE REMEDY. This exclusive remedy will not be deemed to have failed of its essential purpose so long as Arcflash Labs is willing and able to repair or replace any defective product, or refund the purchase price, in the prescribed manner. In the event Arcflash Labs fails to provide the Buyer with free repair or replacement, or refund the purchase price as aforesaid, Arcflash Labs' entire liability shall not exceed the amount paid by the Buyer to Arcflash Labs for its purchase of the defective product. THIS WARRANTY IS EXCLUSIVE AND IN LIEU OF ALL OTHER WARRANTIES NOT EXPRESSLY SET FORTH HEREIN, WHETHER EXPRESS OR IMPLIED BY OPERATION OF LAW OR OTHERWISE, INCLUDING BUT NOT LIMITED TO ANY IMPLIED WARRANTIES OF MERCHANTABILITY OR FITNESS FOR A PARTICULAR PURPOSE.

Limitations: Products which are purchased from other equipment manufacturers and sold by Arcflash Labs as part of a system or on a resale basis will bear only the original manufacturer's warranty. The above warranty shall not apply to fuses, lamps or other items which are expendable by nature, unless otherwise provided.

IN NO EVENT SHALL ARCLASH LABS BE LIABLE FOR ANY INDIRECT, SPECIAL, INCIDENTAL, TORT, PERSONAL INJURY, PROPERTY, CONSEQUENTIAL OR OTHER DAMAGES, INCLUDING BUT NOT LIMITED TO DAMAGE TO OR LOSS OF PROPERTY OR EQUIPMENT, PHYSICAL INJURY, DEATH OR HARM TO GOODWILL OR BUSINESS REPUTATION DIRECTLY OR INDIRECTLY ARISING FROM THE SALE, HANDLING, OR USE OF THE PRODUCT, OR FROM ANY OTHER CAUSE RELATING THERETO. Arcflash labs shall not be liable to the Buyer for any claims, demands, injuries, damages, actions or causes of action whatsoever based on negligence or strict liability. Arcflash Labs shall have no liability of any kind under this Limited Warranty unless the Buyer commences an action against Arcflash Labs within 1 month of the date the cause of action accrues.

Unless otherwise agreed in writing by an authorized representative of Arcflash Labs at Arcflash Labs' headquarters in San Diego, California, the products sold hereunder are not intended for use in connection with any nuclear facility or activity. If so used, in the event any damage, injury or contamination occurs, Arcflash Labs disclaims any responsibility of every kind, and the user of the products shall indemnify Arcflash Labs and hold Arcflash Labs harmless from any and all liability for any such damage or contamination whatsoever arising out of any such use, including liability in tort or strict liability.

WARRANTY CLAIM PROCEDURE: In the event the products purchased hereunder prove defective, the Buyer shall notify Arcflash Labs' Service Department in writing at its offices in San Diego, California of the claimed defect, and such notice shall include the model and serial number of each such product, as well as the number and date of invoice therefore. Upon receipt of this information, Arcflash Labs will send notification to the Buyer as to the service arrangements and will provide written authorization and shipping instruction, and the Buyer shall return the products to Arcflash Labs, transportation prepaid, in accordance with such shipping instructions. If, after inspection, Arcflash Labs determines the defect is a result of misuse, mishandling, installation, abnormal condition of operation, unauthorized repair or modification, or due to Buyer's failure to install, maintain or operate the products in compliance with the written instruction, all necessary materials, labor and other expenses shall be for the account of the Buyer at Arcflash Labs' standard repair rates. Any products returned to Arcflash Labs for replacement shall become the property of Arcflash Labs.

The Buyer shall be responsible for all costs of shipping, customs clearance and other related charges in connection with Arcflash Labs' repair or replacement of products located outside the continental United States pursuant to this Limited Warranty.

The validity, performance and interpretation of this Limited Warranty shall be governed by the internal laws (and not the laws of conflicts) of the State of California. All disputes arising in connection with this limited Warranty shall be resolved, if not sooner settled, by a court of competent jurisdiction located in California, U.S.A.

Updated: 08/2022

Copyright © 2022 by Arcflash Labs, LLC. All rights reserved. Under copyright laws, neither the documentation nor the software may be copied, photocopied, reproduced, translated, or reduced to any electronic medium or machine readable form, in whole or in part, without the prior written consent Arcflash Labs, LLC except in the manner described in the documentation

IT IS STRONGLY ADVISED TO READ THIS ENTIRE MANUAL
FAILURE TO ADHERE TO THESE PROCEDURES COULD RESULT IN
PERSONAL INJURY OR CATASTROPHIC DAMAGE TO THE EMG-02



- TREAT THE EMG-02 AS YOU WOULD A FIREARM. NEVER POINT IT AT ANYTHING OR ANYONE YOU DO NOT INTEND TO DESTROY.
- ALWAYS ENSURE THE POWER SWITCH IS SET TO THE OFF POSITION BEFORE INSERTING THE FUSE OR BATTERY.
- NEVER STICK FINGERS OR ANY FOREIGN MATERIAL INTO THE VENT HOLES.
- DO NOT FIRE ROUNDS SHORTER THAN 0.75" IN LENGTH OR SMALLER THAN 0.25" IN DIAMETER

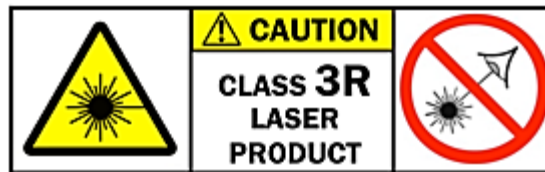

1. Introduction

The Arcflash Labs EMG-02 (Electro-Magnetic Gun – 02) is a 10 stage medium voltage capacitor augmented fully automatic coilgun.

It features 10 stages controlled by a nanosecond-precise microcontroller which allows for firing up to 8 rounds per second full auto, or up to 13 rounds per second in a three round burst mode. The nominal speed of projectiles is 70-75 m/s (230-250 fps).

The EMG-02 is configured to fire steel projectiles (dowel pins) between the diameter range of 0.25-0.3125" and between 0.75-0.875" in length. Arcflash Labs recommends the use of 2575, 51634 or 51678 Magnetic Armatures (sold separately) but ordinary steel dowel pins, ¼" drill bits or even ¼-5/16" round stock cut to proper length should fire from the EMG-02.

The EMG-02 is shipped standard with the MG15A constant-pressure magazine which can hold up to 15 rounds single stacked. It is also compatible with the MG15XL magazine intended for the longer 5/16x7/8" armatures which can deliver up to 20J muzzle energy on target. The EMG-02 is also backward compatible with the SG18 and the MG18 magazines of the SGP-35 and EMG-02. The gun is also shipped standard with a 60v Max Lithium Ion (drill) battery and associated charger. It is also cross-compatible with certain yellow 60v cordless drill batteries. The included battery can provide power for over 300 shots before needing to recharge. The rate of fire of the EMG-02 (up to 8 rounds/sec) is limited by the discharge rate of the lithium ion battery.

1.1 Terminology and Safety

The list below and throughout this manual is a summary of the major hazards associated with the device, but is NOT ALL INCLUSIVE. There are many other hazards associated with the device which are not laid out in this manual. We recommend wearing high voltage, flame retardant gloves at all times when using the device as well as goggles and thick clothing. Never use the device indoors or around flammable materials and always have a fire extinguisher on standby.

The EMG-02 is NOT WATER RESISTANT AND NOT IMPACT SAFE. Exposure to water or dropping from distances greater than 1 foot may cause irreversible damage to the gun, fire, explosion, electrical shock or venting of toxic gas from the battery or capacitors. If the EMG-02 is dropped or exposed to water: discontinue use immediately and return the gun to its manufacturer for repairs.

The following terminology is used throughout this manual for the purpose of denoting important and safety critical information:



An operation, procedure, or practice which if not correctly followed could result in personal injury or loss of life.



An operation, procedure, or practice which if not strictly observed, could result in damage to the device and/or voiding of the device's warranty.

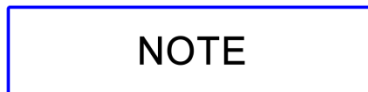

A recommended procedure, suggested practice, or point of additional information which may facilitate the ease of use for the operator, or point out a feature of particular importance which is useful to know, but not safety-critical.

2. Overview of components

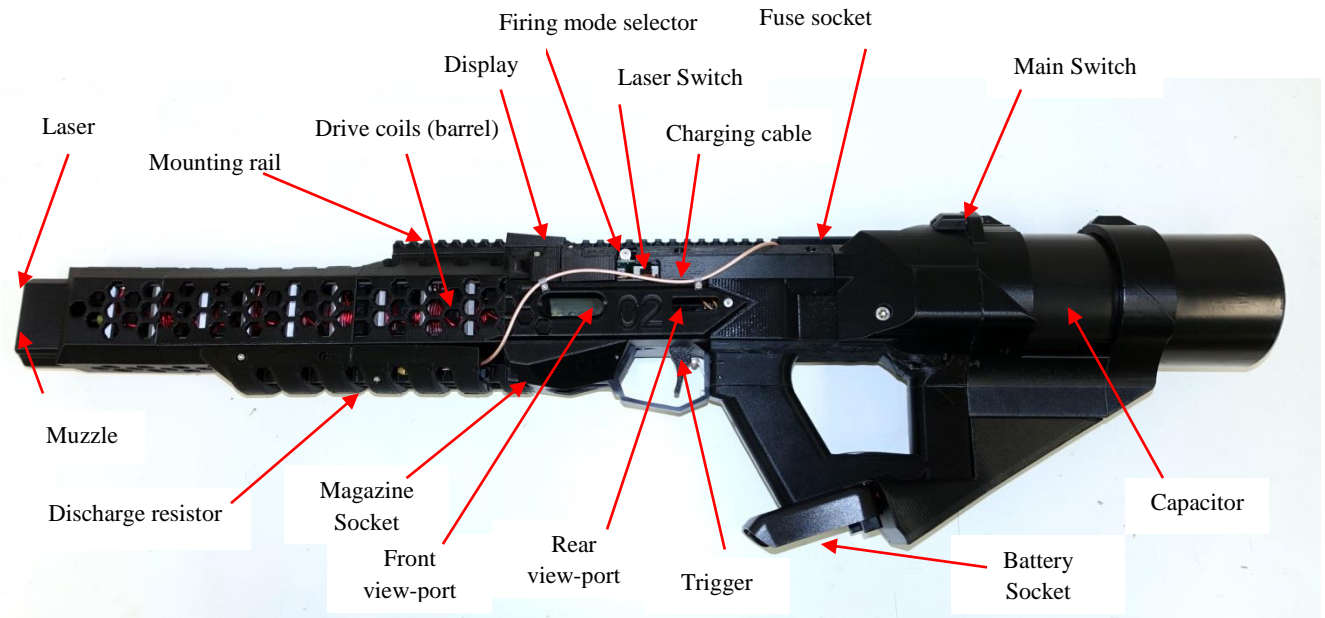

2.1 Barrel



- Muzzle energy is sufficient to break bones, cause serious injury or even death. It goes without saying: never point the gun at anyone or anything you do not intend to destroy.
- Never fire projectiles shorter than 0.75" in length or smaller than 0.25" in diameter – firing such projectiles could result in fire or explosion.
- Class 3R laser. Do not look directly into the laser beam.

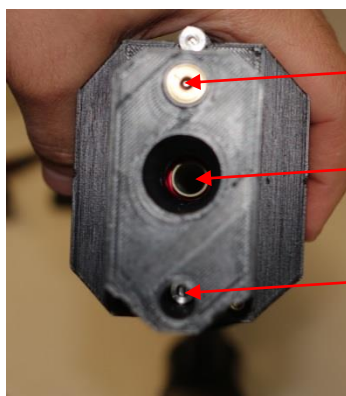

The EMG-02 is a fully automatic electromagnetic gun – its core component is a sequence of optically gated driver solenoids. As a projectile passes through the barrel, it triggers optical gates which send signals back to the microcontroller. The microcontroller quickly interprets these signals and directs the coils to turn on in a precise sequence. This accelerates the projectile down the barrel and out of the gun with an exit velocity of up to 75m/s.

While its muzzle energy is comparable to low end air rifles (around 10-20 joules or 7.5-15 ft-lbs), it should be treated the same way as a firearm. All armatures fired from the EMG-02 have the capacity to penetrate 10% ballistics gel between 2-4" and could result in potentially lethal injuries. Never point the device at anything you don't want to destroy. Treat it as loaded at all times.

The device operates at medium voltage (60V), but carries extremely high amperage (1600A+) during a shot, which is converted to high voltage (650V+) inside the drive coils. While most of the components experiencing these transient high voltage spikes are protected from the user, it is advised that you should never touch any internal components of the gun during a shot, especially those near the barrel. 650V is more than enough to cause serious electrical shock, personal injury or death.

It is important to **never fire projectiles shorter than 0.75" in length or smaller than 0.25" in diameter**. Doing so puts excessive stress on the power semiconductor switching components due to a low inductance configuration of the drive coils. This increases flyback voltage and switching current due to the lower reluctance of the smaller ferromagnetic mass. To put it bluntly: **IF YOU FIRE ROUNDS OUTSIDE OF THESE DESIGN PARAMETERS, THE POWER SEMICONDUCTORS ABOVE THE BARREL WILL EXPLODE.**

Above the barrel is the laser aperture, which is a 650nm <5mW laser pointer for indoor aiming assistance (class IIIR). Do not look directly into the laser.

2.2 User-facing electronic components



- Take care to protect the exposed components (laser switch, charging cable, firing mode switch and main switch) from excessive force. Never rest the gun in a position where these components are stressed.

The EMG-02 has a few user-facing electronic components, around which the user should exercise caution. These components are the laser switch, firing mode switch, main switch, charging cable, and discharge resistor.

It is important to protect all user-facing components from water, dust and contamination. It is due to the fragility of the components that this EMG-02 is still considered a "Beta Test" version as some components are still vulnerable to damage if care is not taken to protect them.

Projectiles are pushed out of the magazine by a pulsed solenoid, known as the injector. On the EMG-02 the injector solenoid body is an internal component and not visible from the exterior of the gun. The injector piston (the moving part of the injector) is visible from the front view-port and rear view-port. In the rear view-port, the injector has a spring loaded mechanism

which allows it to return to its home position. It is important to ensure that no debris enters the front or rear view ports as this could cause feeding issues.

2.3 Discharge resistor

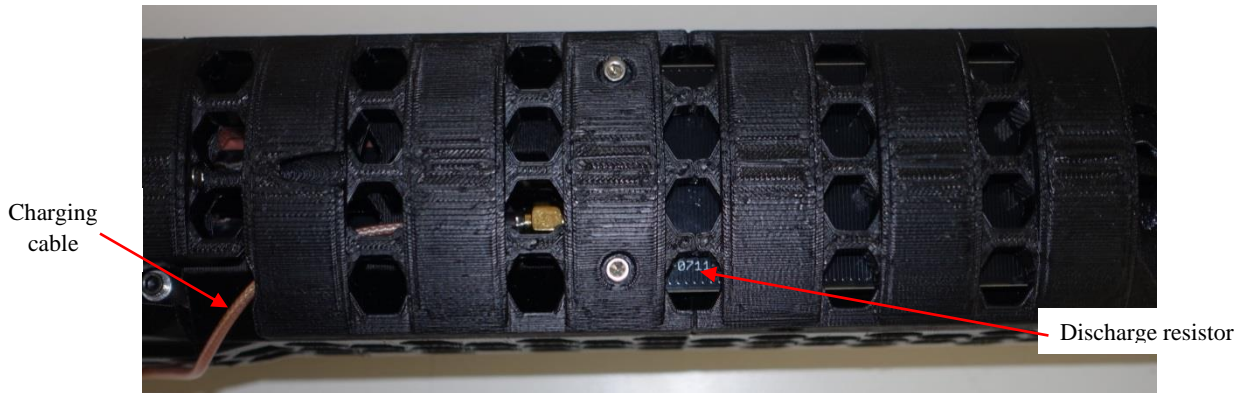

The discharge resistor is a large plate that can be seen under the vents of the barrel which capacitor's energy into heat when the gun is powered off, and also heats up when the gun is powered on. The DCL may heat to over 60°C if the gun is powered off or on in rapid succession. While there is a hand guard to protect the user from the elevated temperature of the discharge resistor, it is important to consider the temperature of the discharge resistor in hot environments or when toggling the main switch as temperatures over 100 °C may cause damage to the polymer barrel structure.

2.4 Main fuse

The main fuse of the EMG-02 is a 40A automotive fuse which acts as a protection against certain types of over-current. If the gun shuts down and fails to restart, a user may attempt to replace the fuse if it has blown. As with all electronic devices: make sure the power is switched off before inserting the fuse or battery.

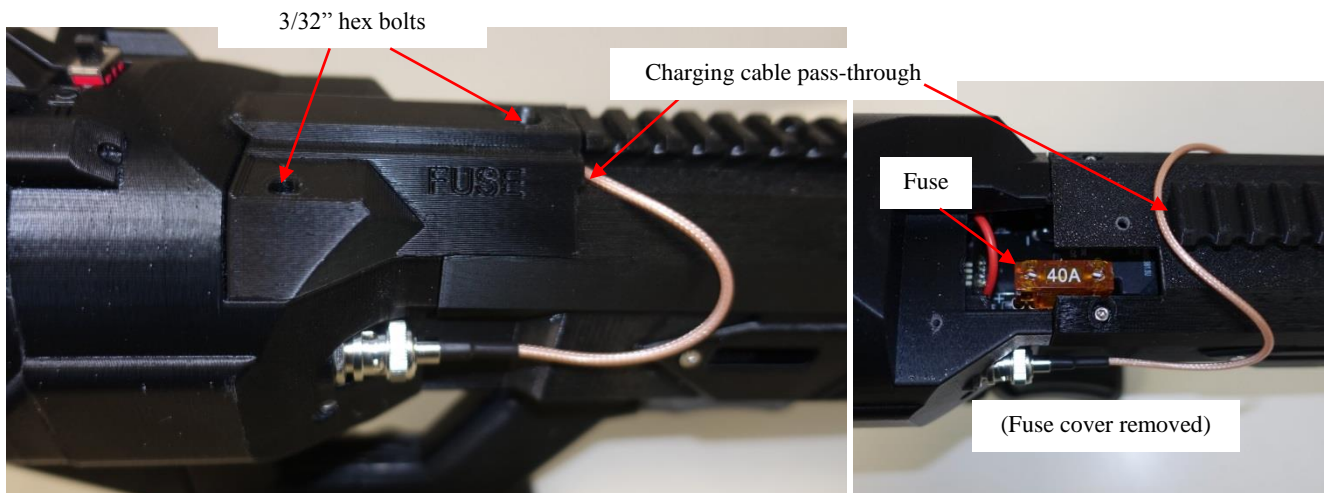

The fuse can be replaced by unscrewing the two 3/32" hex bolts with a standard allen key. Underneath the fuse cover the fuse can be pulled and replaced like any standard automotive fuse. Under ordinary operating conditions, the fuse should not need to be serviced.

If the fuse is replaced by the user or the fuse cover removed, it is important to replace the fuse cover paying special attention to not pinch the charging cable and ensure it is seated in its passthrough notch before applying force to the hex bolts.

2.5 Main switch



- Always ensure the main switch is in the **OFF** position before inserting the battery.
- Always ensure the main switch is in the **OFF** position before removing the battery.
- Do not rapidly toggle the main switch with the battery inserted as this could cause excessive heat buildup in the discharge resistor or damage to internal circuitry.
- After the main switch is toggled (on->off or off->on) **wait at least 60 seconds** before toggling again.

The main switch of the EMG-02 controls both the power electronics and the discharge resistor. It has two modes: ON and OFF.

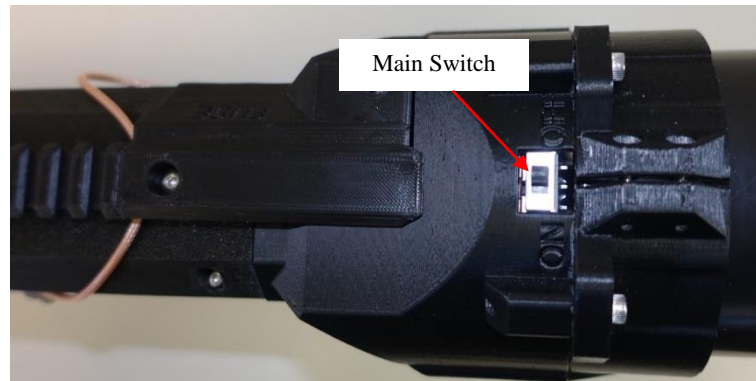

When the switch is placed in the ON position, the battery will be connected to the main electronics of the gun and the capacitors will be commanded to charge by the microcomputer. The microcontroller will charge the capacitors through the charging cable. There are two high current relays inside the EMG-02 which toggle the flow of current during startup. The user may hear several clicks as the unit starts up. The first relay toggles the flow of charge into or out of the capacitor through the resistor and charging cable, the second relay toggles the main high current bus between the capacitor/battery and coils. When the EMG-02 shuts down, the first resistor is de-energized and enters into a failsafe (discharge) mode, allowing charge to flow out of the capacitor, through the cable and resistor and complete a circuit to ground. When the EMG-02 starts up, the same relay allows charge to flow from the battery through the same resistor and into the capacitor.

This system allows the EMG-02 to fail into a capacitor shorted (safe) configuration where the capacitor will always be discharge as long as the unit is de-energized with the battery removed. However, because the discharge resistor serves double duty as both a charging and

discharging resistor, it is important to not toggle the main switch rapidly and allow the resistor to cool for at least 60 seconds between toggles.

2.6 Display/Firing Mode Selector/Laser Switch

The display shows the velocity of the prior shot, the battery percentage/voltage and also shows the current and available firing modes of the gun. There are four modes: SAFE, SINGLE, BURST, and AUTO.

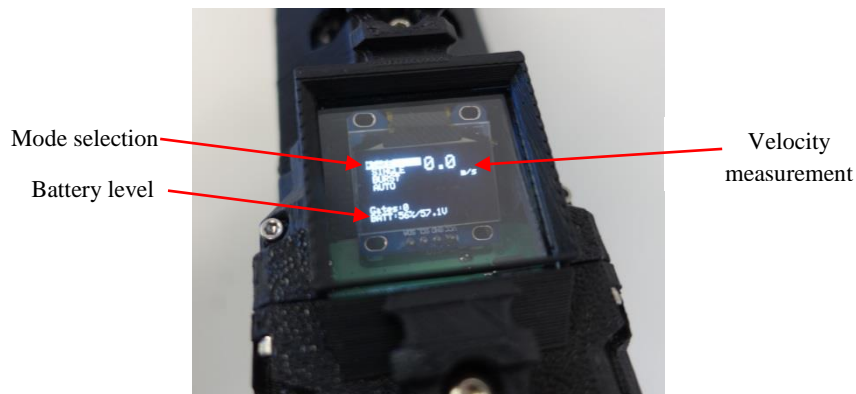
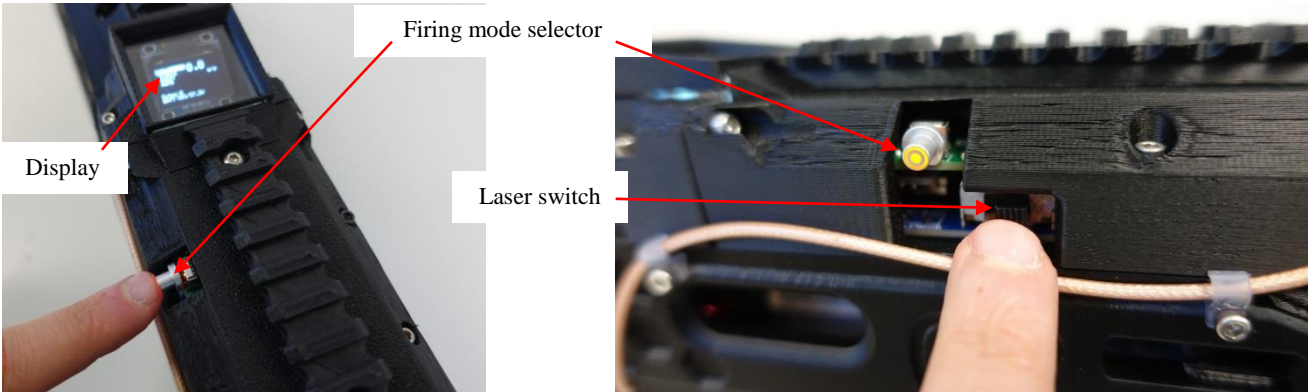

To adjust the firing mode, simply press inward on the firing mode selector until the desired firing mode is selected. NOTE: The firing mode selector button may look slightly different on later batches of the EMG-02.

Below the firing mode selector, there is a toggle switch which activates the laser at the front of the barrel. When toggled rearward, the laser is active. When toggled forward, the laser is de-activated. When active the laser will illuminate continuously until toggled off.

In the SAFE mode, the gun will not fire and will display a warning should the user depress the trigger.

In the SINGLE mode, the gun will fire a single shot semi-automatically once per trigger pull.

In the BURST mode, the gun will fire three shots (at a rate of ~13 rounds per second) in a burst while the user holds down the trigger. If the user releases the trigger mid-burst, subsequent shots will not fire.

In the AUTO mode, the gun will fire continuously (at a rate of ~8 rounds per second) as long as the user holds down the trigger.

At the bottom of the display above the battery level indicator, there is a “Gates” diagnostic indicator, this is for troubleshooting and indicates the status of the photogates within the barrel.

2.7 Battery



- The EMG-02 uses a large Lithium Ion battery. Large lithium batteries can catch fire or release gas if stored improperly. Always store in a cool, dry environment.

The EMG-02 uses a Lithium Ion battery. You know the drill. Big scary battery. Hazards include shock, fire, explosion or venting of toxic gas. Always store the gun and battery in a cool, dry environment indoors, away from any flammable materials.

2.8 Magazines



- The EMG-02 uses a similar magazine retaining mechanism to SGP, GR and other EMG series accelerators. Inserting the magazine should be done in a fluid motion. There is no switch or button required to insert or remove the magazine, a ball detent retainer holds the magazine securely in place.

- If the magazine has trouble feeding rounds or the gun becomes jammed frequently, it is recommended to remove all armatures from the magazine, then depress the follower with a 1/8” steel rod or long screwdriver, then spray the cavity with WD-40 or light oil. Manually actuate the follower a few times to spread the oil throughout the magazine. Proper lubrication will improve armature feeding.

The EMG-02 uses a proprietary magazine design and retaining mechanism which was designed to accommodate a 15 or 18-round 3D-printed magazine (the MG18, MG15A or MG15XL). These magazines use constant pressure springs to store up to 18 0.25x0.75” projectiles or 15 0.31x0.75” or 15 0.31x0.875” armatures. The magazine socket on the EMG-02 is backwards compatible with the SG18 and MG18 magazines. The MG15A and MG15XL magazines will only fit in the EMG-02 and not in any other accelerator.

Only use the designated armature with its respective magazine as shown below:

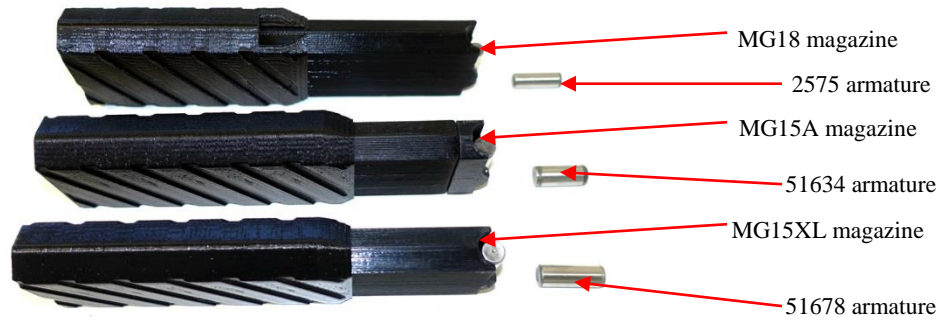

Usage of improper armatures in magazines could result in misfires.

2.9 Capacitor



- The EMG-02 contains a large 0.33F capacitor capable of storing up to 600J of energy
- The capacitor may become unsafe if struck, cut, or severely dented

The EMG-02 contains a large electrolytic capacitor at the rear which is used as a buttstock for the accelerator. The capacitor is attached to the barrel by two large copper bus-bars internal to the unit. The capacitor is capable of delivering several thousand amperes in burst current.

There are two electrical safety mechanisms within the gun which protect the capacitor from reverse bias and overvoltage, and an internal burst valve near the fuse cover in case both safeties were to fail or physical damage to the capacitor resulted in pressure buildup.

If the capacitor becomes dented, gouged, or deeply scratched we recommend discontinuing to use the EMG-02 and contact Arcflash Labs for repairs or assessment. Light scratches to the capacitor case (the black plastic surrounding the aluminum can) are not hazardous unless the aluminum can itself is damaged or punctured.

There is no inherent danger to touching or handling the capacitor's exterior shell so long as there is no apparent physical damage to the capacitor or to the EMG-02.

The capacitors require approximately 6 seconds to charge during power-up and 6 seconds to discharge during power-down.

3. Operation

3.1 Startup



- ALWAYS ENSURE THE POWER SWITCH IS SET TO OFF BEFORE INSERTING THE BATTERY.
- DO NOT INSERT A LOADED MAGAZINE UNTIL THE GUN IS POWERED ON AND POINTED IN A SAFE DIRECTION.

1. Insert battery into battery socket



2. Toggle the main switch from the OFF position to the ON position.

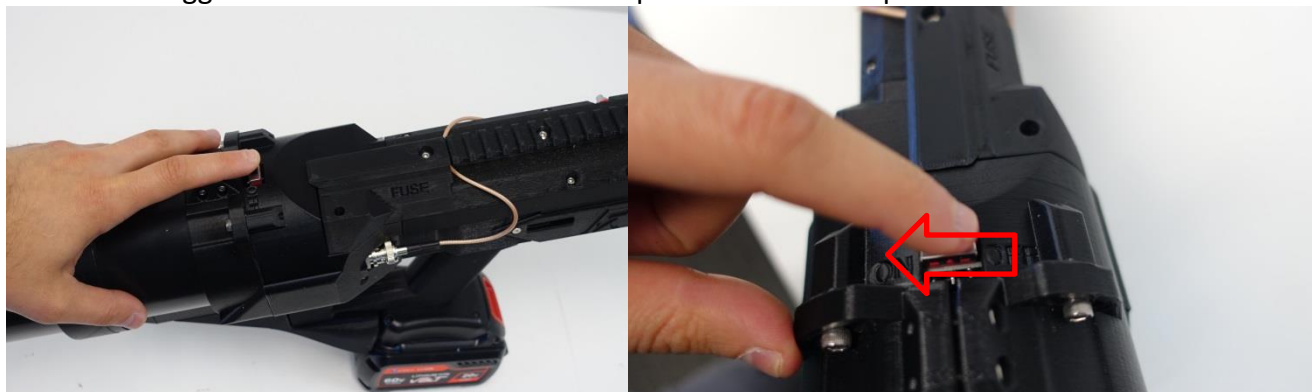

3. Wait for the capacitor to charge. The firing mode selector button should illuminate.

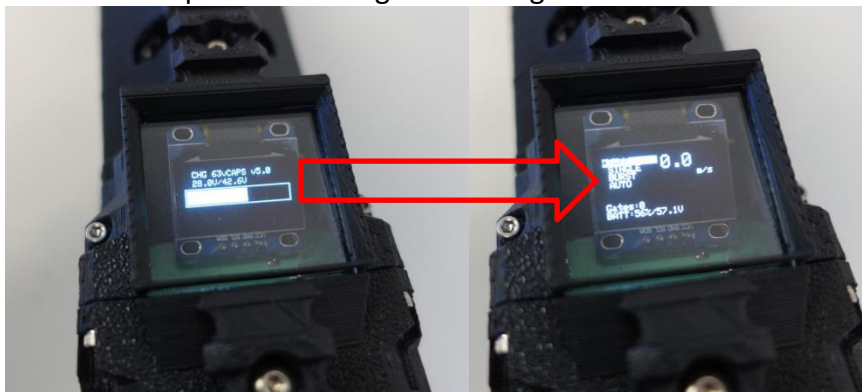

4. Ensure the mode is set to SAFE, velocity displays 0.0 m/s and Gates displays "0". If any of these parameters is different than expected at startup the gun may have experienced a malfunction and should be shut down and inspected for damage.

Expected parameters at startup:

“SAFE”

“0.0 m/s”

“Gates: 0”

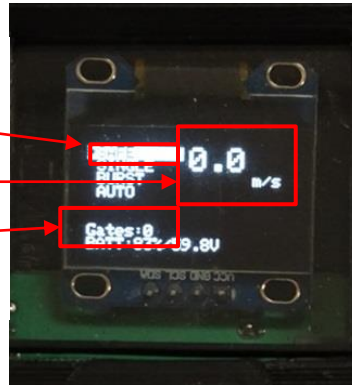

5. Observe the front view port: there should be a red illumination and the magazine well should be clear and free of any armatures or debris.

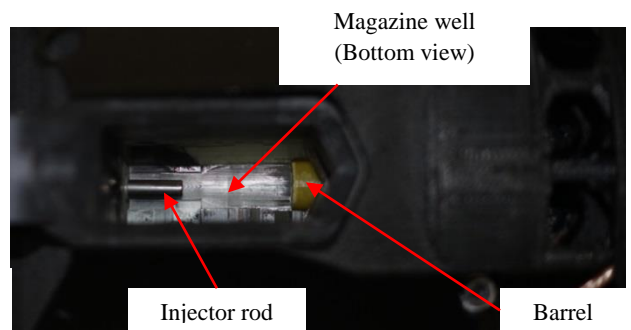
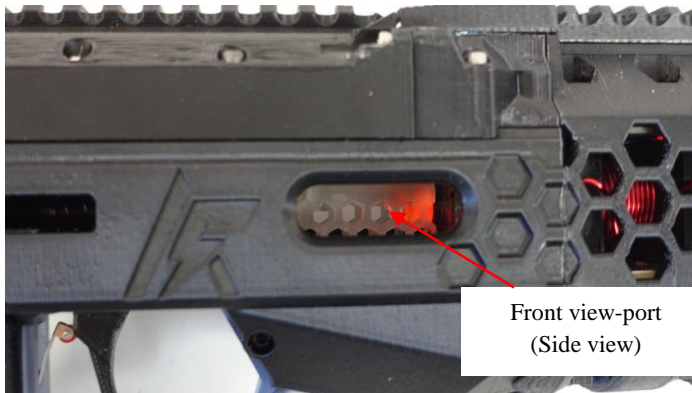

3.2 Inserting a magazine

1. Always ensure the gun is powered up and pointed in a safe direction before inserting a magazine. There is no slide or chamber on the EMG-02. The active round in the magazine itself acts as the chambered round.
2. The magazine is held in place by a self-locking detent. There is no magazine release – merely insert the magazine into the magazine well in a single fluid motion.



3. Ensure the magazine is properly seated and the armature is properly aligned with the barrel (yellow tube). If the silver armature is not visible through the front view port (or is not properly aligned with the tube) after a magazine has been inserted, the round may not feed properly during the first shot but should still feed properly on subsequent shots.

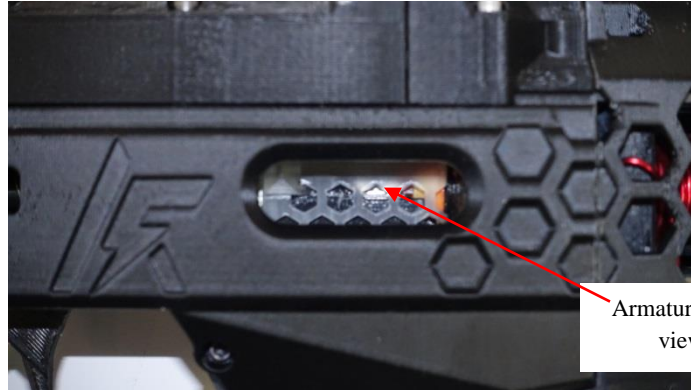

3.3 Shutdown

1. Place the gun in SAFE mode.
2. Firmly grasp the magazine and remove it from the gun. Ensure the no armatures remain within the magazine well.



3. Toggle the main switch from the ON to the OFF position.



4. Place the gun on a safe, stable surface and point the gun in a safe direction, then squeeze the battery release inward and pull the battery away from the battery socket to remove it.



Battery Release

5. Replace the EMG-02 and battery in its included carrying case.

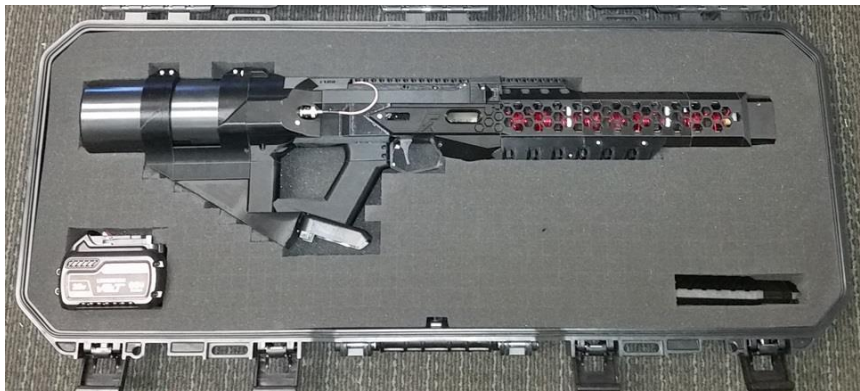

3.4 Battery Charging

1. Unpack the charger and connect the balance charging unit to the AC power supply.
2. Simply insert the battery into the socket of the charging unit. The red light should begin flashing



- Once the charging indicator light turns solid, the battery is fully charged and can be removed from the charging unit.



Charging indicator

4. Software

The software in this device is not intended to be user-serviceable. In fact, tampering with the EMG-02 software is expressly discouraged and will immediately void any express or implied warranties. Any attempt to modify the software may render the gun unusable or unsafe. Arcflash Labs, LLC assumes absolutely no responsibility for units which have had their software modified by the end user.

5. Hardware Specifications

Accelerator Specifications

Primary power source	1x 15S Li-Ion – 63V
Power supply	Proprietary (11kW)
Capacitors	1x 0.33F MV electrolytic
Switches	Proprietary (IGBT-based)
Projectile	variable caliber, alloy steel, 4.6-8.5g
Magazine Capacity	15-18 rounds
Battery Capacity	Up to 300 shots per battery
Rate of fire	8.0 rounds/sec (auto) 13 rounds/sec (burst)
Muzzle velocity	Up to 75 m/s
Muzzle energy	Up to 20 J
Range	15 – 25 m (optimal/max)
Efficiency	4.45%

Physical Dimensions

Barrel length	13.0"
Bore	0.32"
Physical Dimensions	32.5" x 9.0" x 4.5"
Overall Weight (unloaded, no battery)	9.7 lbs

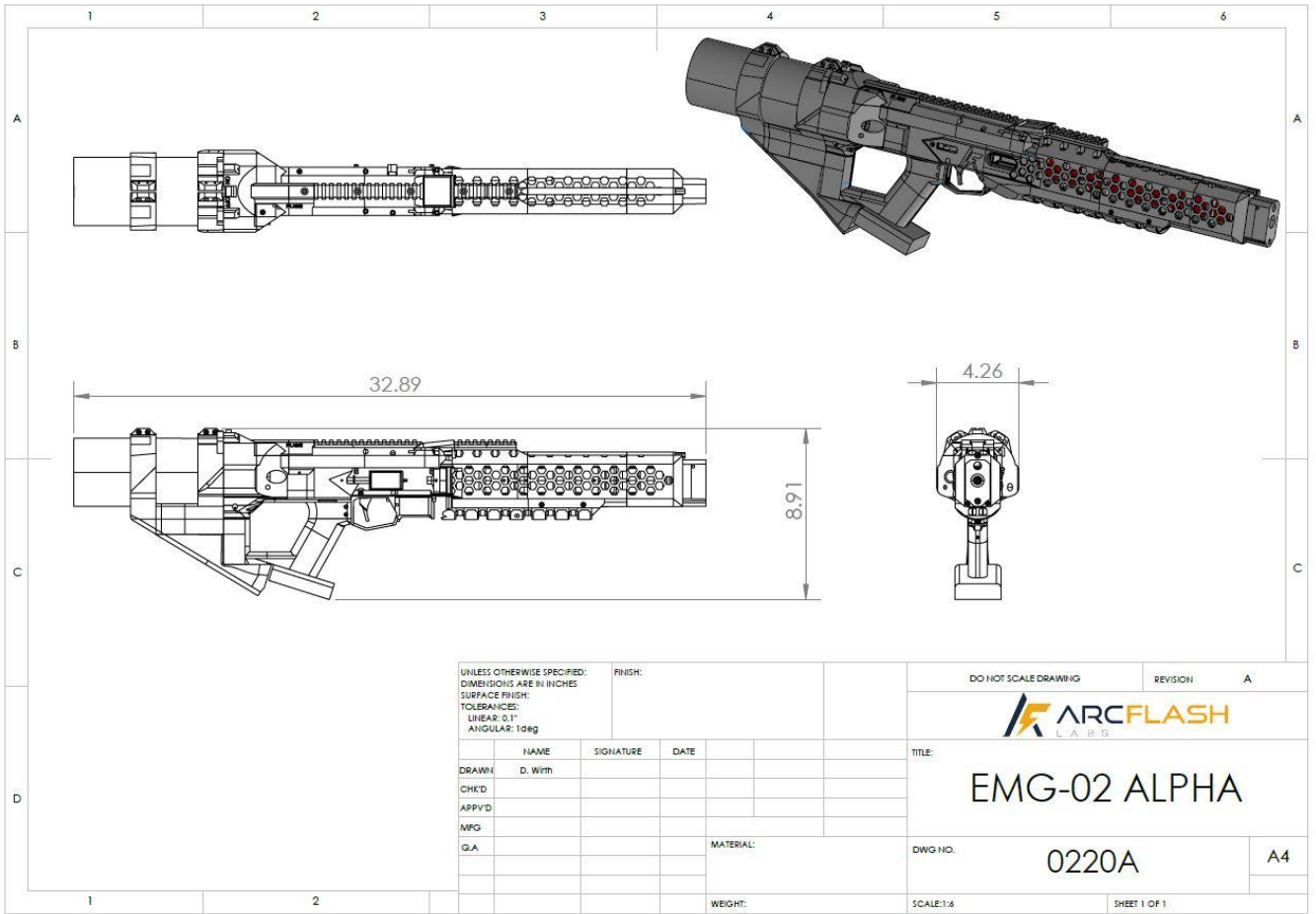

UNLESS OTHERWISE SPECIFIED: DIMENSIONS ARE IN INCHES SURFACE FINISH: TOLERANCES: LINEAR: 0.1" ANGULAR: 10kg				FINISH:	
DRAWN:	NAME	SIGNATURE	DATE		
CHKD:	D. With				
APP'VD:					
MFG:					
Q.A.				MATERIAL:	
				WEIGHT:	

DO NOT SCALE DRAWING		REVISION	A
			
TITLE:			
EMG-02 ALPHA			
DWG NO.	0220A		A4
SCALE: 1:6	SHEET 1 OF 1		